

New A-board guidelines

Bristol City Council is proposing to introduce new guidelines on A-boards placed on the footway



Why we need guidelines

Bristol City Council supports businesses as key drivers for the local economy and recognise that in order for businesses to thrive and grow they must promote and advertise themselves.

However there has been a trend for lots more A-boards over recent years, with these getting bigger and sometimes placed in unsuitable locations.

This poses difficulties for pedestrians including pushchair users and people with disabilities.

We need to strike a balance between allowing the important need of businesses to advertise whilst protecting and enhancing the street environment for pedestrians to encourage walking as a healthy mode of travel. Therefore the council is proposing new guidelines regarding A-boards.



Key areas of new guidelines

This Draft Policy relates to A-boards and other similar advertising boards. The definition of A-boards includes all types of adverts, directional/ information signs and applies solely to boards placed upon the footway. It does not apply to boards on private property, including privately owned shopping centres.

The policy sets out guidelines for what is considered acceptable such as:

- All businesses are permitted to have one A-board up to 80cm in height and 50cm in width outside their premises subject to;
- signs placed on the public highway would need to leave at least 1.8 metres of clear footway.

It also sets out the council's enforcement policy dealing with breaches of highway law.

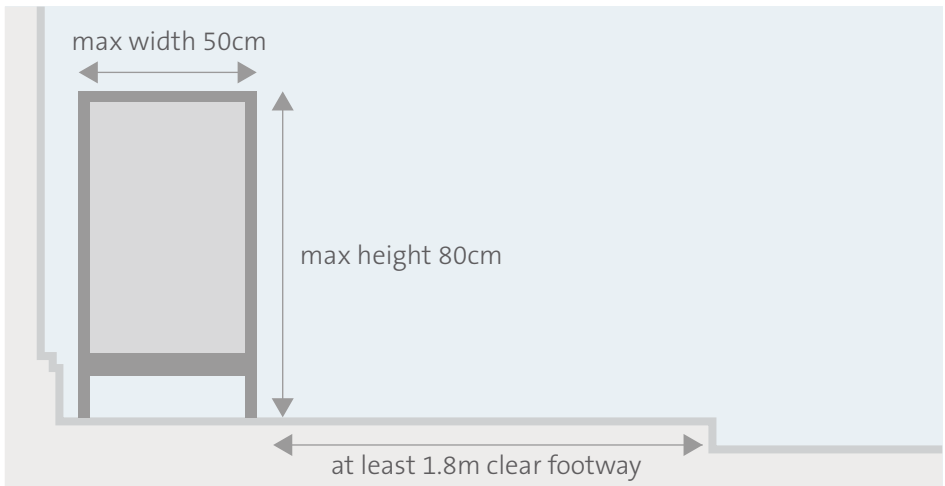

Where can I found out more?

The full draft A-boards policy document can be found at:

www.bristol.gov.uk/a-boards

Or contacting City Transport at Bristol City Council requesting the document either by:

Phone: **0117 903 6701**

Fax: **0117 903 6540**

Email:

city.transport@bristol.gov.uk

Write to:

**City Transport,
Bristol City Council,
Wilder House,
Wilder Street,
BRISTOL
BS2 8PH**

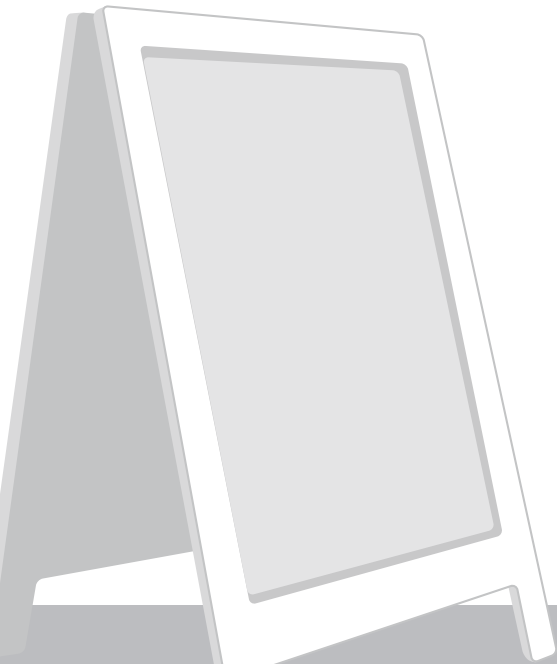
- 
- If you would like this information in a different format, for example Braille, audiotape, large print or computer disc, or community languages, please contact us at the address above or telephone 0117 903 6701.